

# Electrical Connection for LEDD-01

## 1. Electrical connection

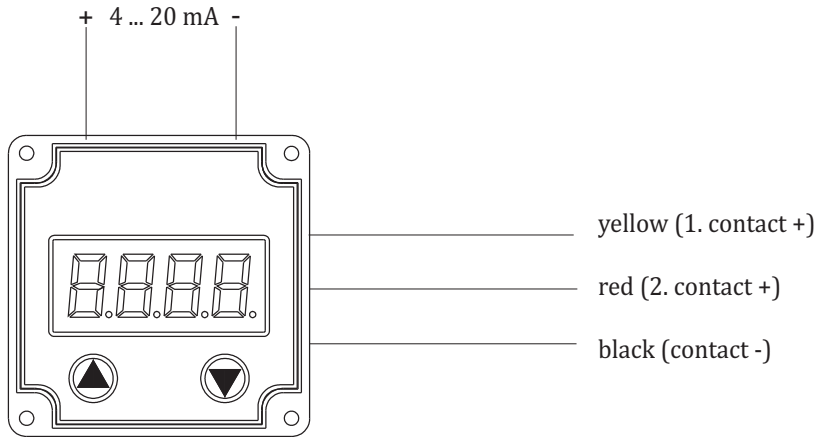

## 2. Connection for only 1 contact (1 switch)

### 2.1 Directly connection with road (max. contact-current: 50 mA)

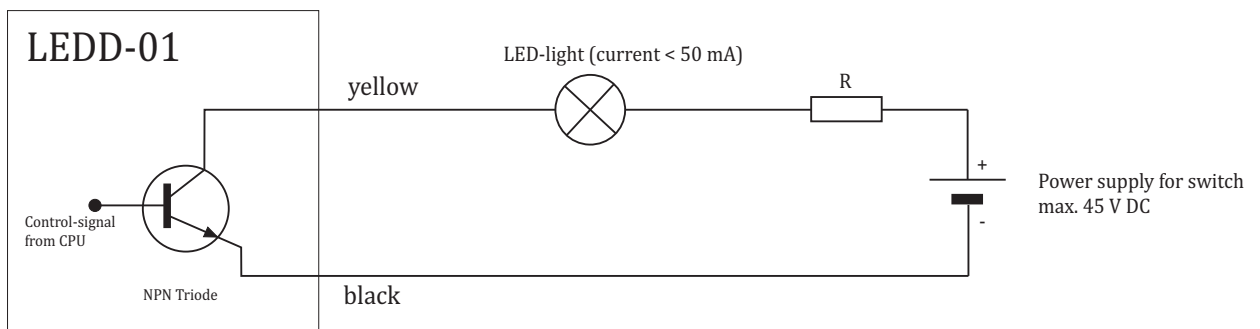

### 2.1 Connection with big road (contact-current > 50 mA), using a relay

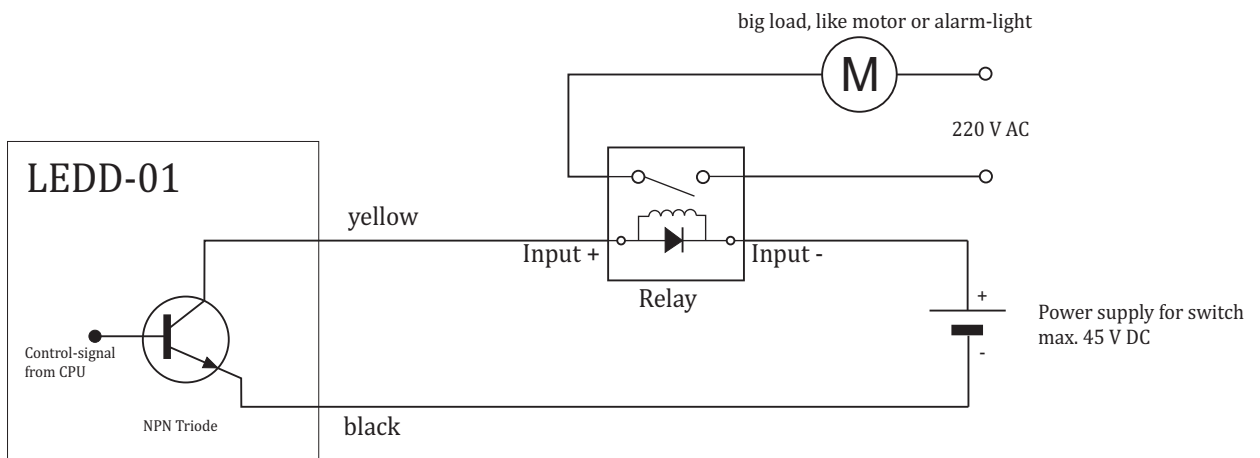

## 2. Connection for 2 contacts (2 switches)

### 2.1 Directly connection with load (max. contact-current: 50 mA)

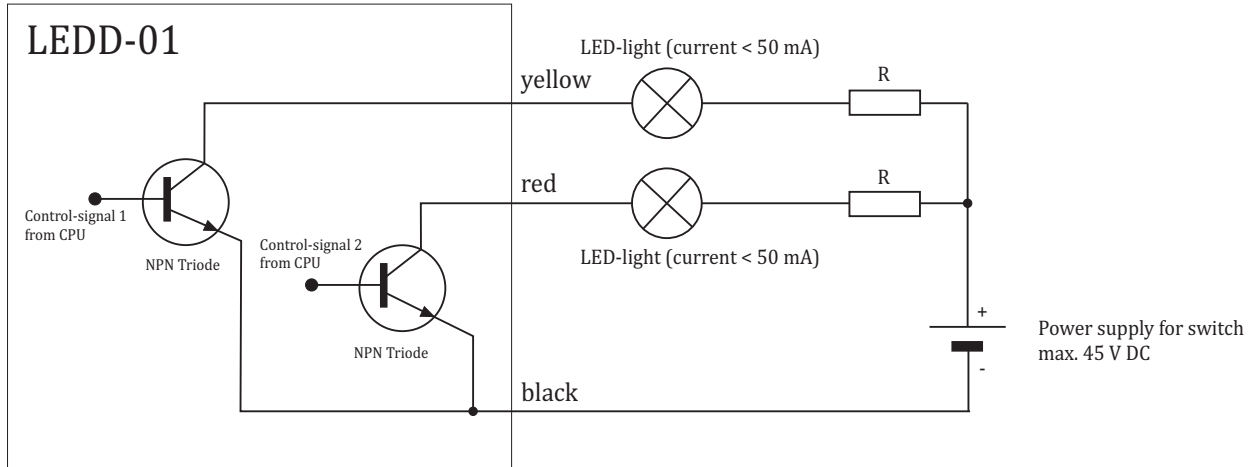

### 2.1 Connection with big load (contact-current > 50 mA), using a relay

