

Mess-, Regel- und  
Überwachungsgeräte  
für Haustechnik,  
Industrie und Umweltschutz

Lindenstraße 20  
74363 Güglingen  
Telefon +49 7135 102-0  
Service +49 7135-102-211  
Telefax +49 7135-102-147  
info@afriso.de  
www.afriso.de



## Operating instructions

**Magnetic piston type pressure gauges  
for differential pressure – high over-  
load protection**

**Type: MAG 80/100 Dif**

# 88002312 - # 88041312

**Magnetic diaphragm pressure gauges  
for very low differential pressure**

**Type: MAG 115 Dif**

# 88002311 - # 88021311

- + Read instructions before using device!
- + Observe all safety information!
- + Keep instructions for future use!

# Table of contents

1	This instruction manual.....	3
1.1	Precautions .....	3
1.2	Explanation of symbols and typeface .....	3
2	Safety.....	4
2.1	Intended use.....	4
2.2	Predictable incorrect application .....	4
2.3	Safe handling .....	4
2.4	Staff qualification .....	4
2.5	Modifications to the product .....	4
2.6	Usage of spare parts and accessories.....	5
2.7	Liability information .....	5
3	Product description.....	6
3.1	Scope of delivery.....	6
3.2	Function principle .....	6
4	Technical specifications.....	8
4.1	MAG 80/100 Dif.....	8
4.2	MAG 115 Dif.....	11
4.3	Electrical contacts .....	14
4.4	Reed contact (SPDT) .....	15
5	Transport and storage .....	15
6	Mounting and commissioning.....	16
6.1	Prior to mounting.....	16
6.2	Mounting MAG .....	16
6.3	Panel mounting (MAG 115 Dif) .....	17
6.4	Wall mounting or pipe mounting (option) .....	18
7	Operation.....	19
7.1	Zero correction (MAG 115 Dif).....	19
7.2	Contact settings (MAG with electrical contact) .....	20
8	Troubleshooting.....	21
9	Decommissioning, disposal.....	22
10	Returning the device.....	22
11	Warranty .....	22
12	Copyright .....	23
13	Customer satisfaction .....	23
14	Addresses.....	23



# 1 This instruction manual

This instruction manual is part of the product.

- ▶ Read this manual before using the product.
- ▶ Keep this manual during the entire service life of the product and always have it readily available for reference.
- ▶ Always hand this manual over to future owners or users of the product.

## 1.1 Precautions

**WARNING TERM**Type and source of the danger are shown here.



- ▶ Precautions to take in order to avoid the danger are shown here.

There are three different levels of warnings:

Warning term	Meaning
<b>DANGER</b>	Immediately imminent danger! Failure to observe the information will result in death or severe injuries.
<b>WARNING</b>	Possibly imminent danger! Failure to observe the information may result in death or severe injuries.
<b>CAUTION</b>	Dangerous situation! Failure to observe the information may result in minor or severe injuries as well as damage to property.

## 1.2 Explanation of symbols and typeface

Symbol	Meaning
<input checked="" type="checkbox"/>	Prerequisite for an activity
▶	Activity consisting of a single step
1.	Activity consisting of a several steps
↘	Result of an activity
•	Bulleted list
Text	Indication on display
<b>Highlighting</b>	Highlighting



## 2 Safety

### 2.1 Intended use

The **magnetic piston type pressure gauges MAG 80 Dif and MAG 100 Dif** may only be used for differential pressure measurement of gaseous and liquid, non-adhesive media.

The **Magnet-magnetic diaphragm pressure gauge MAG 115 Dif** may only be used for differential pressure measurement of air or compatible gases.

- ▶ Use MAG only within the specified pressure application range (see table 1, page 9).

Any use other than the application explicitly permitted in this instruction manual is not permitted.

### 2.2 Predictable incorrect application

MAG must never be used in the following cases:

- Hazardous areas/potentially explosive atmospheres
- Application in an environment subject to a magnetic field.

### 2.3 Safe handling

MAG represents state-of-the-art technology and is made according to the pertinent safety regulations. Each product is subjected to a function and safety test prior to shipping.

- ▶ Operate MAG only when it is in perfect condition. Always observe the operating instructions, all pertinent local and national directives and guidelines as well as the applicable safety regulations and directives concerning the prevention of accidents.

Extreme environmental conditions have negative effects on the function of the product.

- ▶ Protect MAG against heavy vibration.

### 2.4 Staff qualification

The product may only be mounted, commissioned, operated, maintained, shut down and disposed of by qualified, specially trained staff.

Electrical work may only be performed by trained electricians and in compliance with all applicable local and national directives.

### 2.5 Modifications to the product

Changes or modifications made to the product by unauthorised persons may lead to malfunctions and are prohibited for safety reasons.



## 2.6 Usage of spare parts and accessories

Usage of unsuitable spare parts and accessories may cause damage to the product.

- ▶ Use only genuine spare parts and accessories of the manufacturer.

## 2.7 Liability information

The manufacturer shall not be liable in any form whatsoever for direct or consequential damage resulting from failure to observe the technical instructions, guidelines and recommendations.

The manufacturer or the sales company shall not be liable for costs or damages incurred by the user or by third parties in the usage or application of this product, in particular in case of improper use of the product, misuse or malfunction of the connection, malfunction of the product or of connected devices. The manufacturer or the sales company shall not be liable for damage whatsoever resulting from any use other than the use explicitly permitted in this instruction manual.

The manufacturer shall not be liable for misprints.

### 3 Product description

#### 3.1 Scope of delivery

##### MAG 115 Dif



- 1 Three fixing clamps for panel mounting
- 2 Two 1/8 NPT (A) blind plug for closing unused connections
- 3 Three screws M3 x 4
- 4 Three tapping screws type AB 4 x 19
- 5 Two 1/8 NPT (A) adapters for hose connection and lower or rear connections

##### MAG with electrical contact

- Cable glands

##### Option wall mounting

- Mounting plate with fixing clamp

#### 3.2 Function principle

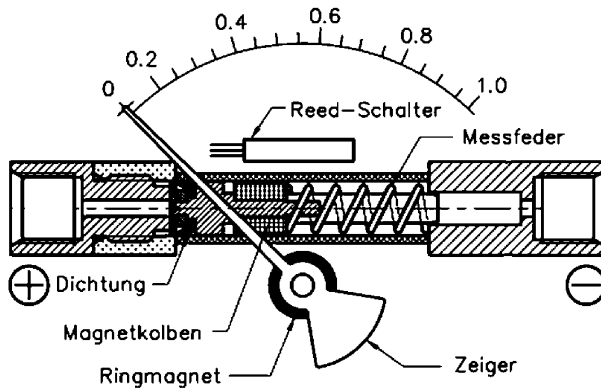

Fig. 1: Function principle MAG 80/100 Dif

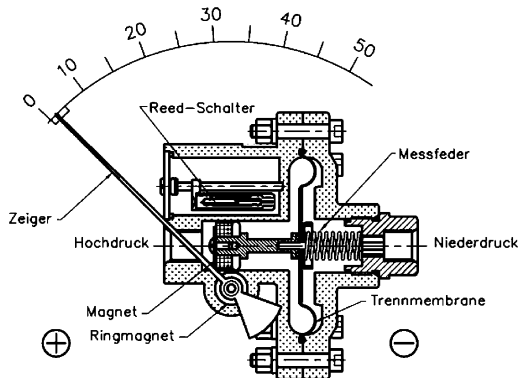

Fig. 2: Function principle MAG 115 Dif

High and low pressure are separated by a sensor unit consisting of a magnetic piston, a Buna seal (MAG 80/100 Dif) or a diaphragm (MAG 115 Dif) and a measuring spring. The pressure difference causes a movement of the sensor unit against the measuring spring proportional to the pressure change.

A ring magnet which is contained in a separate chamber of the housing and which is isolated from the pressures is rotated by the magnetic coupling in accordance with the linear movement of the sensor unit. A pointer mounted to the ring magnet indicates the differential pressure on the dial.

**MAG with electrical contacts:** Reed contacts are located next to the pressure chamber; they are activated by the magnetic field of the sensor unit.



## 4 Technical specifications

### 4.1 MAG 80/100 Dif

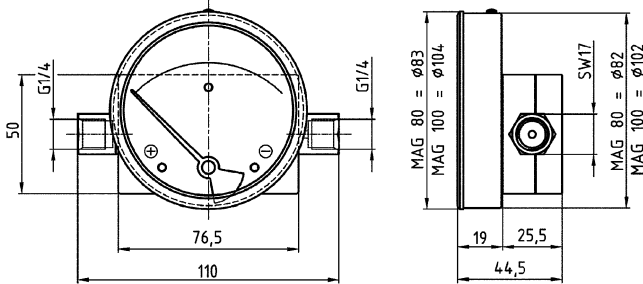

Fig. 3: Connection on left and right sides

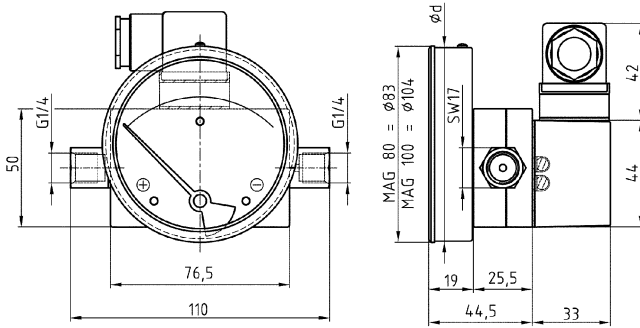

Fig. 4: Connection on right and left side; with electrical contact

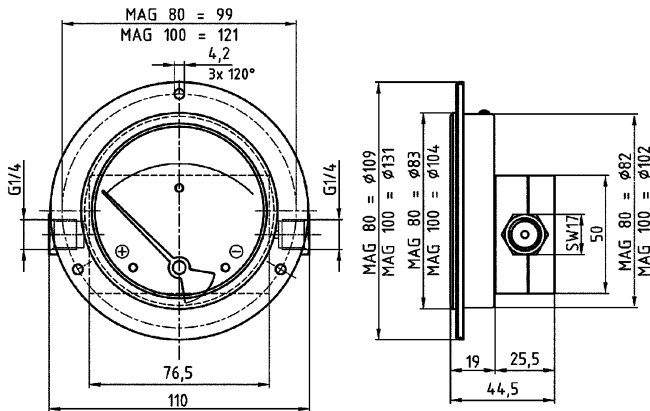

Fig. 5: Connection on right and left sides; 3-hole fixing, panel mounting bezel



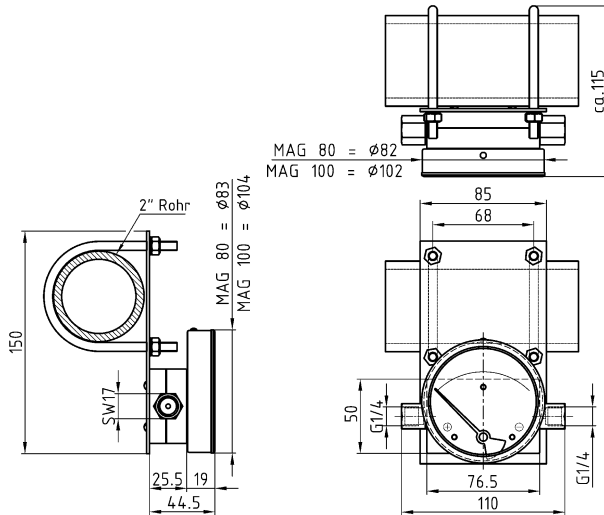

Fig. 6: Mounting plate and fixing clamp

Table 1: Technical specifications MAG 80/100 Dif

Parameters	Value
<b>General specifications</b>	
Housing $\varnothing$ MAG 80 Dif MAG 100 Dif	80 mm 100 mm
Panel cut out: MAG 80 Dif MAG 100 Dif	$\varnothing 84$ mm $\varnothing 105$ mm
Connection	2 x G $\frac{1}{4}$ female thread, width across flats SW 17
Range (EN 837-3/5)	0/0.25 bar to 0/10 bar
Dial	Dial marking black/red (bar/psi), scale angle 90°
Static pressure	Standard: Max. 100 bar Option: Max. 250/400 bar
Overpressure safety	Up to the maximum static pressure at both sides
Accuracy	$\pm 3$ % of full scale value at increasing differential pressure



Parameters	Value
Degree of protection	IP 65 as per EN 60529
<b>Operating temperature range</b>	
Ambient	0 °C to 80 °C
Medium	Max. 100 °C
<b>Material (parts not wetted)</b>	
Housing	Stainless steel 1.4301 with rubber sealing ring at the front
Connection cover	Plastic, glass-fibre reinforced, black
Dial	Aluminium, white
Pointer	Aluminium, black
Window	Instrument glass
<b>Material (wetted parts)</b>	
Connection	Stainless steel 1.4401
Measuring element (compression spring)	Stainless steel 1.4310
Magnetic piston	Stainless steel 1.4401/strontium ferrite
Seal	NBR



## 4.2 MAG 115 Dif

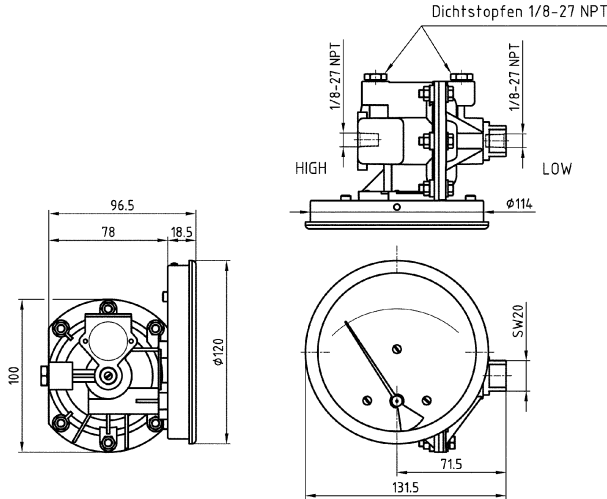

Fig. 7: Connection on right and left sides or on rear

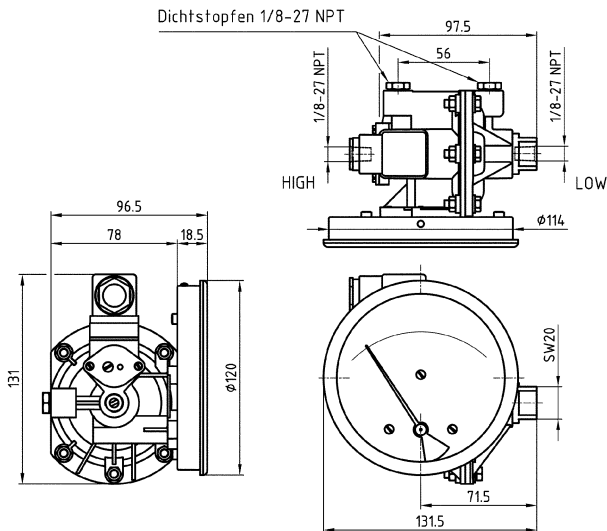

Fig. 8: Connection on right and left sides or on rear; with electrical contact

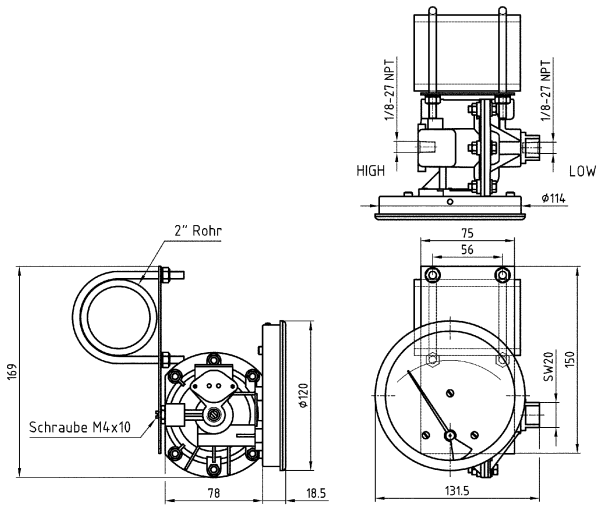

Fig. 9: Mounting plate and fixing clamp



Table 2: Technical specifications MAG 115 Dif

Parameters	Value
<b>General specifications</b>	
Housing Ø	115 mm
Panel cut out	Ø 115 mm
Connection	2 x 1/8 NPT female thread or 2 x hose connection 5 mm (as required by using the enclosed adapters)
Range (EN 837-3/5)	0/0.25 mbar to 0/100 mbar
Dial	Dial marking black, scale angle 90° (first graduation after zero at 15 % of full scale value)
Static pressure	Max. 2.4 bar
Overpressure safety	Up to the maximum static pressure at both sides
Accuracy	±3 % of full scale value at increasing differential pressure
Degree of protection	IP 65 as per EN 60529
<b>Operating temperature range</b>	
Ambient	0 °C to 60 °C
Medium	Max. 60 °C
<b>Material (parts not wetted)</b>	
Housing	Stainless steel 1.4301 with rubber sealing ring at the front
Dial	Aluminium, white
Pointer	Aluminium, black
Window	Instrument glass
<b>Material (wetted parts)</b>	
Connection	Nylon 66, glass-fibre reinforced
Measuring element: Diaphragm Compression spring	NBR Stainless steel 1.4310
Magnet	Strontium ferrite



Parameters	Value
Seal	NBR

### 4.3 Electrical contacts

*Table 3: Technical specifications electrical contact*

Parameters	Value
Version	Reed contact, single, changeover contact (SPDT)
Switching voltage	AC/DC 30 V
Switch rating	AC 3 VA
Current	AC/DC 300 mA
Switching hysteresis	Approx. 5 %
Adjustment range: MAG 80/100 Dif MAG 115 Dif	35-100 % of full scale value 40-80 % of full scale value
Electrical connection	Connector DIN 43650-A



## 4.4 Reed contact (SPDT)

Table 4: MAG 80/100 Dif: Terminal block connection

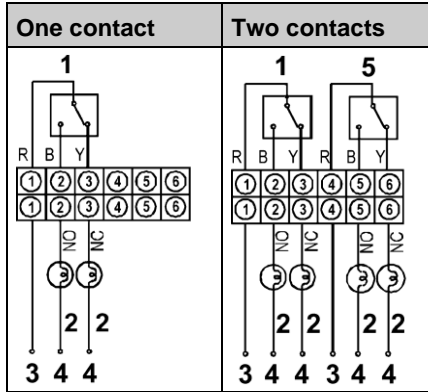

- 1 Contact no. 1
- 2 Load
- 3 L or (+)
- 4 N or (-)
- 5 Contact no. 2
- R Red
- B Black
- Y Yellow

Table 5: MAG 80/100 Dif and MAG 115 Dif: One contact

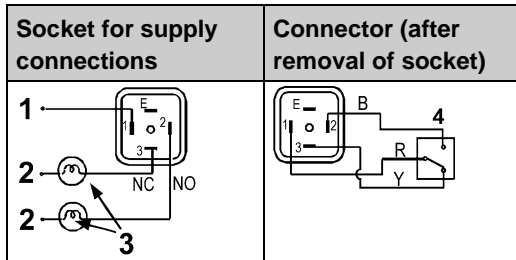

- 1 L or (+)
- 2 N or (-)
- 3 Load
- 4 SPDT contact
- R Red
- B Black
- Y Yellow

## 5 Transport and storage

### CAUTION

Damage to MAG device due to improper transport.



- ▶ Do not throw or drop MAG.

### CAUTION

Damage to MAG due to improper storage.



- ▶ Protect MAG from shock when storing it.

## 6 Mounting and commissioning

### 6.1 Prior to mounting

- ▶ Verify compatibility of the medium with the wetted parts. See chapter 4, page 8 for the materials.

The following conditions must be met at the installation site for correct indication:

- Do not expose MAG to heavy vibration or shocks.
- Do **not** use MAG in an environment subject to a magnetic field.
- Within an area of 50 mm around the product, only non-magnetic equipment, parts, etc. may be used. Otherwise, the calibration is influenced.
- If MAG is installed in panels, the panel material must be non-ferrous.

### 6.2 Mounting MAG

1. Unpressurise the system.
2. Install MAG **horizontally**, i.e. align the dial vertically.
3. Verify correct connection of "High pressure" and "Low Pressure", do not interchange the connections.
4. Connect the line for high pressure to the "High" connection and the line for low pressure to the "Low" connection of MAG. Use O rings with male connectors in order to avoid excessive tightening torque and leakage (with parallel threads).

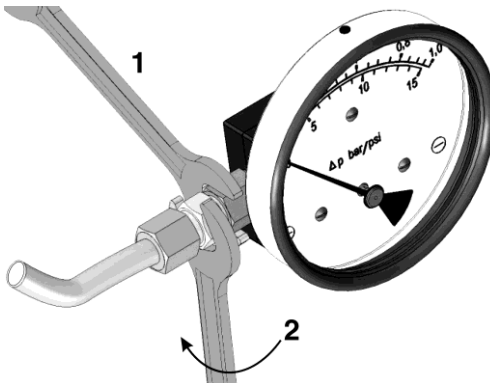

- 1 **Hold** MAG with this spanner.
- 2 **Tighten** MAG with this spanner.

Fig. 10: MAG 80/100: Connection of the lines



5. **MAG 115 Dif:**  
 High pressure: Connect the line from the high pressure source to one of the two high pressure connections.  
 Low pressure: Connect the line from the low pressure source to one of the two low pressure connections.  
 Close the unused connections using the enclosed blind plug.
  6. **MAG with electrical contact:** Use cable with  $\varnothing$  4 or 8 mm.
  7. Ground MAG in compliance with all applicable grounding requirements.
- MAG is ready for operation.

### 6.3 Panel mounting (MAG 115 Dif)

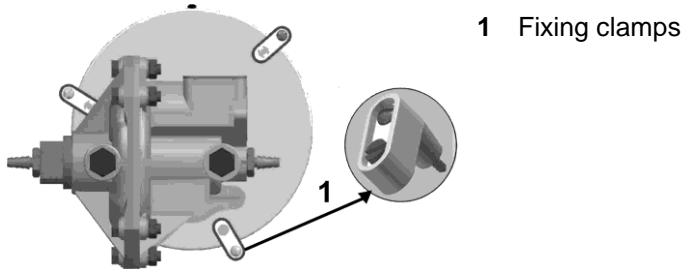
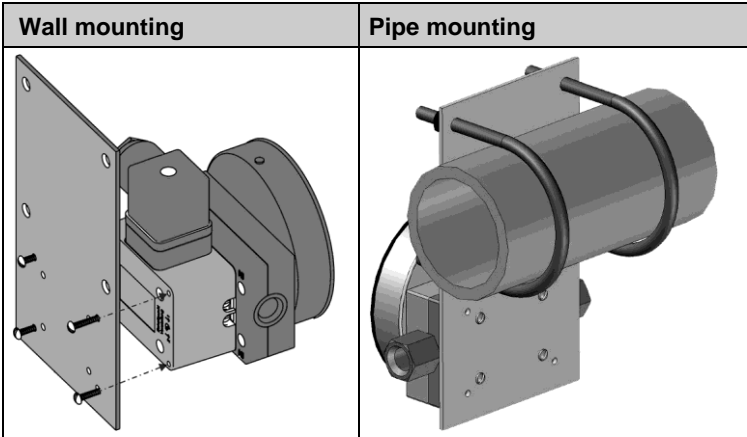

Fig. 11: Panel mounting with fixing clamps MAG 115 Dif



## 6.4 Wall mounting or pipe mounting (option)

Table 6: MAG 80/100 Dif



- ▶ **MAG 115 Dif:** Close rear connections with the enclosed metal plugs.

Table 7: MAG 115 Dif

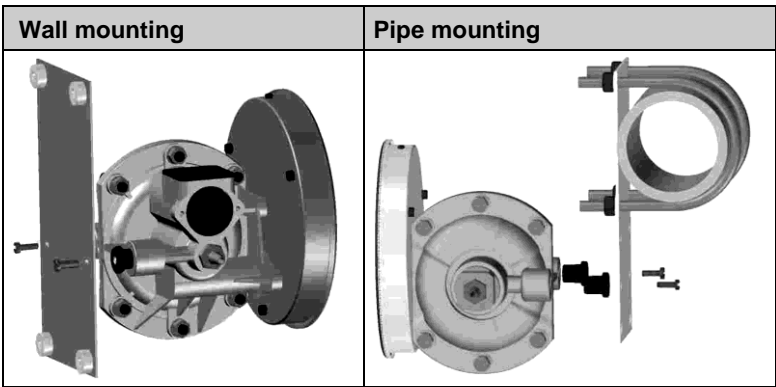



## 7 Operation

---

### CAUTION



#### **Damage to MAG due to improper connection.**

- ▶ Apply high pressure and low pressure to MAG **at the same time** in order to avoid damage to internal parts.
- 

MAG has a piston type sensor unit (MAG 80/100 Dif) or a diaphragm (MAG 115 Dif) which detect the differential pressure.

---

### CAUTION



#### **Damage to the O rings at the male connections and the Buna or Viton seal in the pressure chamber caused by excessive static pressure.**

- ▶ Do not exceed the maximum permissible static pressure specified in chapter 4, page 8.
- 

If the static pressure is within the permissible pressure range, but the differential pressure exceeds the permissible range, this does not cause damage to the device. In such a situation, the pointer is at the utmost right end of the scale.

### 7.1 Zero correction (MAG 115 Dif)

When no pressure is applied, the pointer must be in the tolerance bar at the beginning of the scale. If the pointer is **not** in the tolerance bar when no pressure is applied, you can turn the inlet pressure screw to calibrate the pointer. The adjustment screw is located on the cap at the low pressure side.

Never touch or adjust the screw at the high pressure side!

## 7.2 Contact settings (MAG with electrical contact)

The contacts are usually factory-adjusted in order to save the customer time. However, you can also set the contact on site.

The supply must not exceed the maximum contact rating!

*Table 8: Contact adjustment screw (1)*

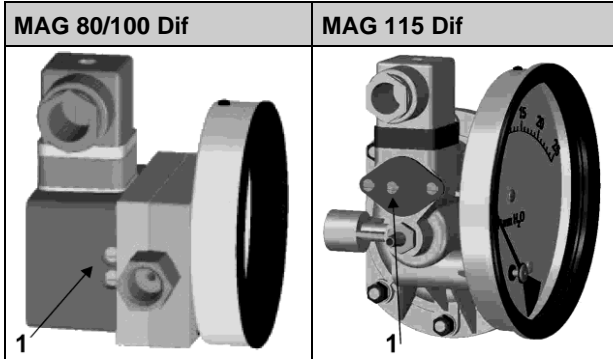

- The contact adjustment screw(1) is located on the plastic cover at the high pressure side.
- Turn the contact adjustment screw counter-clockwise to increase the switching point, turn it clockwise to decrease the switching point.
- One or two attempts may be necessary to obtain the desired switching point.

This adjustment procedure can be performed on a test bench or directly during operation.



## 8 Troubleshooting

**CAUTION** Impact on calibration due to improper assembly of the product.



- ▶ Do not open MAG.

*Table 9: Troubleshooting*

Problem	Possible reason	Repair
MAG indicates incorrect values or no values at all.	<b>MAG 115 Dif:</b> Unused connections not closed.	▶ Verify that the unused connections have been properly closed, see chapter 6.2, page 16.
	Pressure lines have a leak or are clogged.	▶ Verify that the pressure lines have no leaks, that they are not twisted/bent and that they are not clogged.
	Incorrect installation.	▶ Verify that the device has been correctly installed, see chapter 6, page 16.
	External objects or magnetic particles in the pressure chamber.	▶ The devices are clean when delivered. Check the area of the cap at both ends for cleanliness.
	No differential pressure between high pressure side and no pressure side	▶ Filter is new/clean. Wait until differential pressure is generated in the system.
	Other causes.	▶ Send the device to the manufacturer.



## 9 Decommissioning, disposal



1. Dismount the device (see chapter 6, page 16, reverse sequence of steps).
2. To protect the environment, this product must not be disposed of together with the normal household waste. Dispose of the product according to local directives and guidelines.

This product consists of materials that can be reused by recycling firms. The electronic inserts can be easily separated and the device consists of recyclable materials.

If you do not have the opportunity to dispose of the used device in accordance with environmental regulations, please contact us for possibilities to return it.

## 10 Returning the device

In order to protect the environment and our staff, we will transport, check, repair or dispose of returned products only if this is possible without risk to health and environment.

- ▶ Always enclose a declaration of decontamination when returning a device (confirmation that the device is free from hazards)
- ▶ The declaration of decontamination can be downloaded at [www.afriso.com](http://www.afriso.com).

Without a declaration of decontamination, we are unable to process your returned device. Thank you for your understanding.

If the product was operated with hazardous substances:

1. Decontaminate the device in accordance with all pertinent directives.
- ↳ The product is free from hazardous substances.
2. Enclose proof of decontamination in accordance with all pertinent directives when returning the device.

## 11 Warranty

The manufacturer's warranty for this product is 24 months after the date of purchase. This warranty shall be good in all countries in which this product is sold by the manufacturer or its authorised dealers.



## 12 Copyright

The manufacturer retains the copyright to these operating instructions. These operating instructions may not be reprinted, translated, copied in part or in whole without prior written consent.

We reserve the right to technical modifications with reference to the specifications and illustrations in this manual.

## 13 Customer satisfaction

Customer satisfaction is our prime objective. Please get in touch with us if you have any questions, suggestions or problems concerning your product.

## 14 Addresses

The addresses of our worldwide representations and offices can be found on the Internet at [www.afriso.de](http://www.afriso.de).